



Ravaglioli

COMPANY
WITH QUALITY SYSTEM
CERTIFIED BY DNV
= ISO 9001/2000 =

SOLLEVATORI A CILINDRI INTERRATI

IN-GROUND PISTON LIFTS

STEMPEL-UNTERFLURHEBEBÜHNEN

RAV

1110

1120

1125

1130

1140

1150



1958 | 2008



- Sollevatori elettroidraulici predisposti per l'installazione incassata nel pavimento.
- Perfetta sincronizzazione dei cilindri indipendentemente dalla ripartizione del carico.
- Dispositivo di appoggio meccanico ad inserimento automatico e disinserimento pneumatico, a garanzia della massima sicurezza in fase di stazionamento.
- Valvole di sicurezza nei confronti di sovraccarichi e rottura di tubi idraulici.
- Valvola di controllo della velocità di discesa.
- Dispositivi di sicurezza meccanici, idraulici ed elettrici conformi alle Normative Europee.
- Impianto elettrico con circuito di comando in bassa tensione (24 V).
- *Electro-hydraulic lifts designed for recessed installation.*
- *Perfect synchronization between cylinders regardless of load distribution.*
- *Mechanical locking device with automatic engagement and pneumatic release, ensuring maximum safety when lift is in standing position.*
- *Equipped with safety valve to prevent overloading and in case of hydraulic pipe fracture.*
- *Self-controlled lowering speed.*
- *All mechanical, hydraulic and electrical components manufactured in compliance with the respective European Safety Standard.*
- *Low voltage controls (24 V).*
- Elektro-hydraulische Hebebühnen für Unterflur-Einbau.
- Gleichlaufregelung der Stempel unabhängig von der Verteilung des Gewichtes.
- Mechanische Stützvorrichtung mit automatischer Einschaltung und pneumatischer Ausschaltung, um eine maximale Sicherheit im aufgehobenen Zustand zu garantieren.
- Sicherheitsventile gegen Überlastung und Bruch von Hydraulikleitungen.
- Steuerventil für die Geschwindigkeit des Absenkens.
- Mechanische, hydraulische und elektrische Sicherheitseinrichtungen gemäß den Europäischen Normen.
- Elektroanlage mit Niederspannungs-Steuerkreis (24 V).

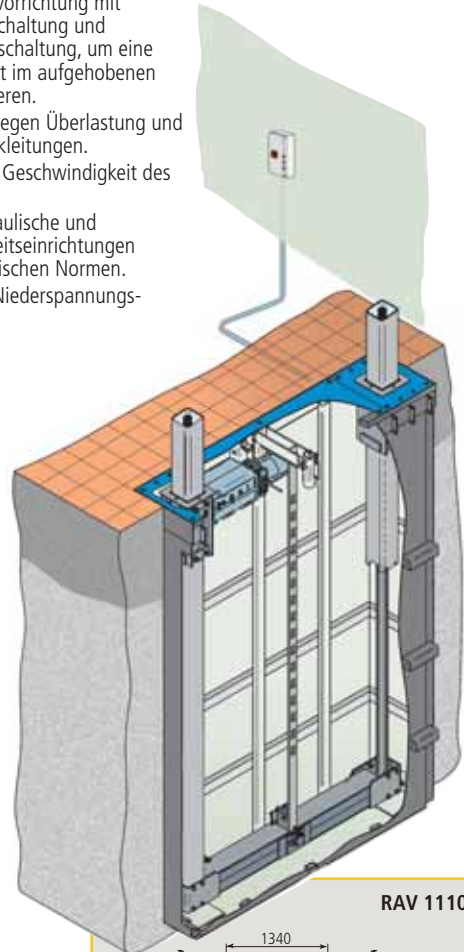

Sollevatore a bracci Version with lifting arms Hebebühne mit Tragarmen

RAV1110K - kg 3.500

Sollevatore a bracci.
Tamponi regolabili in altezza e predisposti per l'alloggiamento rapido di prolunghe.

*Lift with arms.
Pads can be adjusted in height and are suitable for quick housing of extensions.*

Hebebühne mit Tragarmen.
Höhenverstellbare Drehteller mit Stecksystem für Erhöhungen.

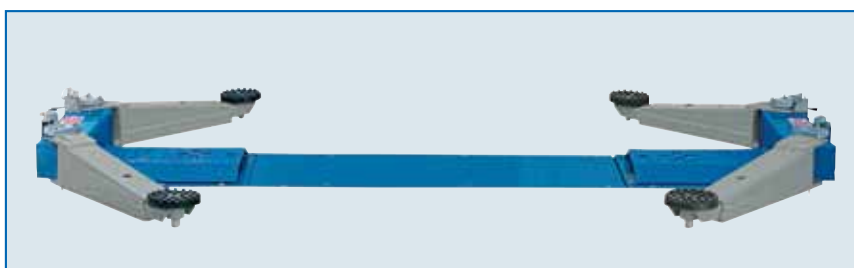

RAV 1110K

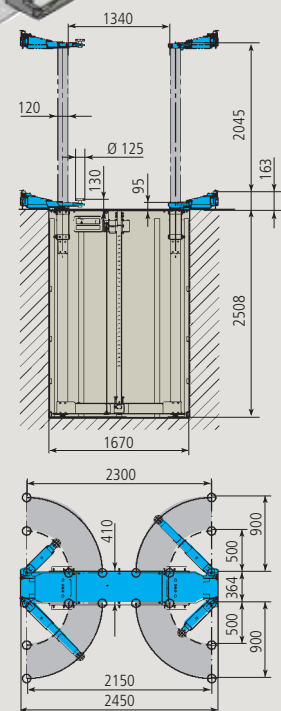

RAV 1110K



RAV1150U - kg 5.000

Sollevatore per auto e furgoni, anche a passo lungo, fino ad un peso di kg.5.000. Il carrello supporto bracci è regolabile in larghezza, consentendo l'utilizzo universale del sollevatore.

Lift for cars and vans, also with long wheel-base, up to an overall weight of 5000kg.

The carriages supporting the arms can be adjusted in width, in order to make the lift suitable for any application.

Hebebühne 5.000 kg fuer PKW uns Lieferwagen, auch mit langem Radstand. Tragarmwagen längs verschiebbar für einen universellen Einsatz.



RAV 1150U

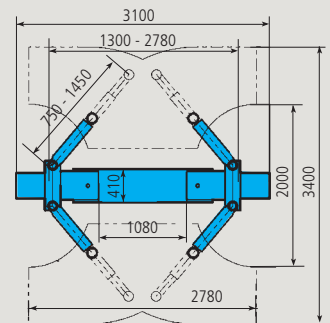
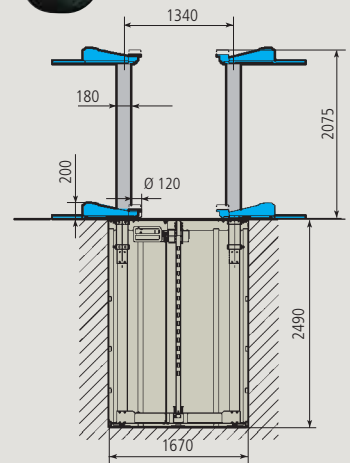

OPTIONS

S 224 A3 (H=80mm)
S 224 A4 (H=140mm)

Distanziali per Fiat Ducato, Peugeot Boxer, Citroën Jumper, VW Crafter (4 pezzi)

Spacers for Fiat Ducato, Peugeot Boxer, Citroën Jumper, VW Crafter (4 pcs)

Abstandstücke für Fiat Ducato, Peugeot Boxer, Citroën Jumper, VW Crafter (4 Stücke)

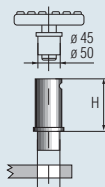

S 305 A9

Distanziali per Mercedes Sprinter, VW LT e Ford Transit (2+2 pezzi)

Spacers for Mercedes Sprinter, VW LT and Ford Transit (2+2 pcs)

Abstandstücke für Mercedes Sprinter, VW LT und Ford Transit (2+2 Stücke)

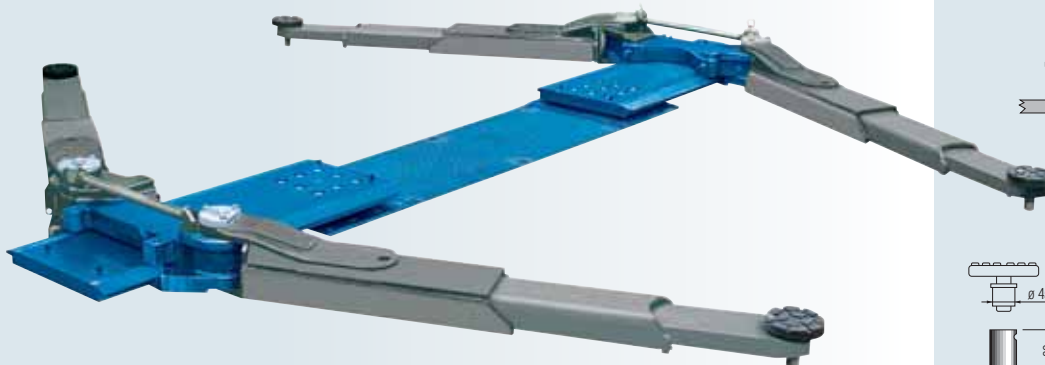
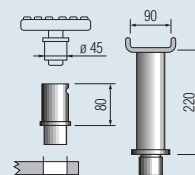



L'altezza minima da terra, garantisce una facile accessibilità al veicolo e permette un rapido posizionamento per il sollevamento. Il limitato ingombro in lunghezza e larghezza lascia libere le aree circostanti il sollevatore, aumentando la sicurezza nella zona di lavoro. Ideale per riparazioni meccaniche, servizio pneumatici e ammortizzatori, è anche una ottima scelta in zona di accettazione.

The minimum height from the floor guarantees easy and rapid positioning of the vehicle on the lift. The limited space required by the lift improves safety of the working area. Ideal for mechanical repairs, tyre shops and rapid fit facilities. It is also a good choice for service reception areas.

Die Mindesthöhe vom Boden ermöglicht eine leichte Zufahrt des Fahrzeugs und eine schnelle Richtigstellung zum Heben. Die geringe Länge und Breite lassen grosse Bewegungsfreiheit um die Bühne und gewährleisten mehr Sicherheit auf dem Arbeitsplatz. Ideal für mechanische Eingriffe, Reifen- und Stossdämpferservice und auch eine optimale Lösung für die Annahme.

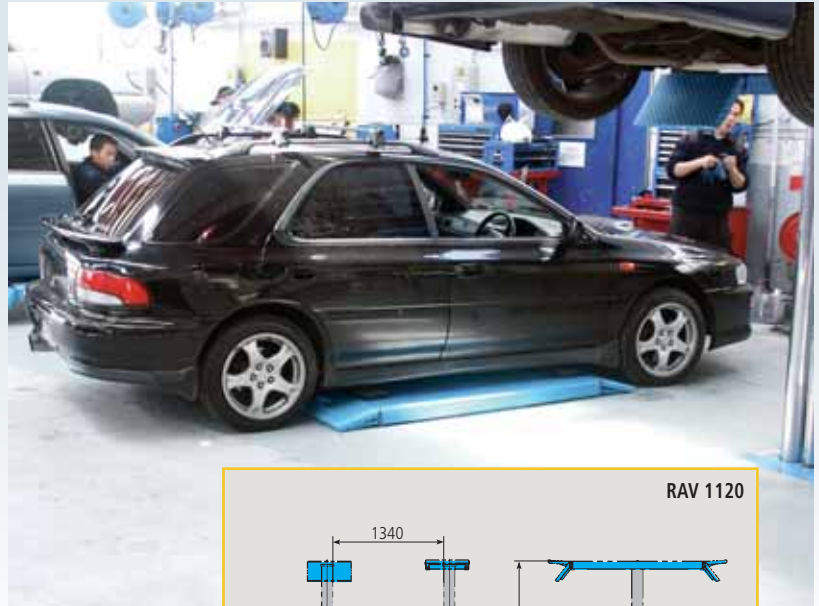

Sollevatore a pedanine Platforms version Hebebühne mit Plattenaufnahmen

RAV1120 - kg 3.500

Sollevatore a pedanine. Le rampe di salita possono essere bloccate rapidamente in posizione orizzontale e servire da prolunghe. Altezza minima 95 mm.

Lift with platforms. The run-up ramps can easily and quickly be blocked in horizontal position to serve as platform extensions. Min. height: 95mm.

Hebebühne mit Flachträgeraufnahmen. Die Auffahrtsrampen können hochgeklappt werden und als Verlängerungen benutzt werden. Auffahrtshöhe 95 mm.

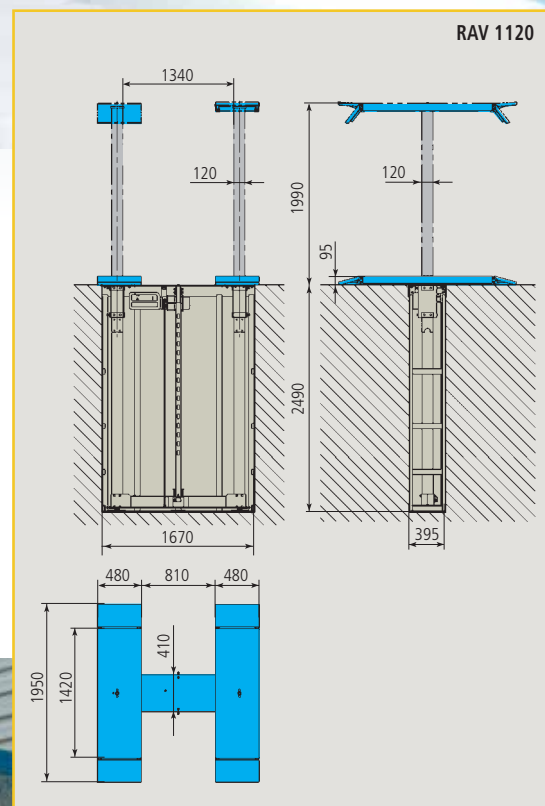

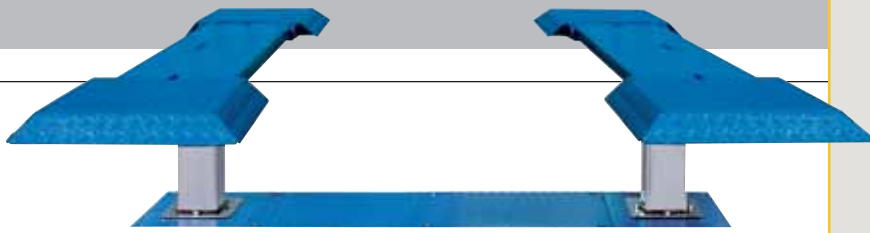

Sollevatore a pedanine
Version with lifting platforms
Hebebühne mit Plattenaufnahmen

RAV1125 - kg 3.500

Sollevatore a pedanine extra basse con altezza di soli 60 mm.
 Pedanine regolabili in lunghezza.

*Lift with extra-low platforms: only 60mm.
 Platforms can be adjusted in length.*

Hebebühne mit Flachträgeraufnahmen 60 mm hoch.
 Aufnahmen sind längs ausziehbar.

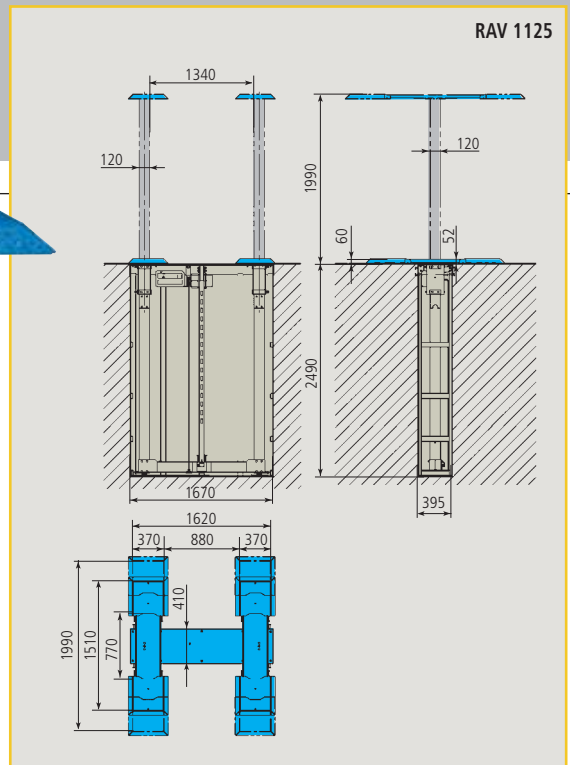

Sollevatore a pedanine con carreggiata variabile
Lift with adjustable track of pick up supports
Hebebühne mit seitenverstellbare Aufnahmeplatten

RAV1125M - kg 3.500

Sollevatore con pedanine regolabili sia in lunghezza che in larghezza.
 Altezza minima di 95 mm.

*Lift with adjustable platforms: both in length and in width.
 Min. height: 95mm.*

Hebebühne mit Flachträgeraufnahmen 95 mm hoch.
 Aufnahmen sind längs und seitlich ausziehbar.

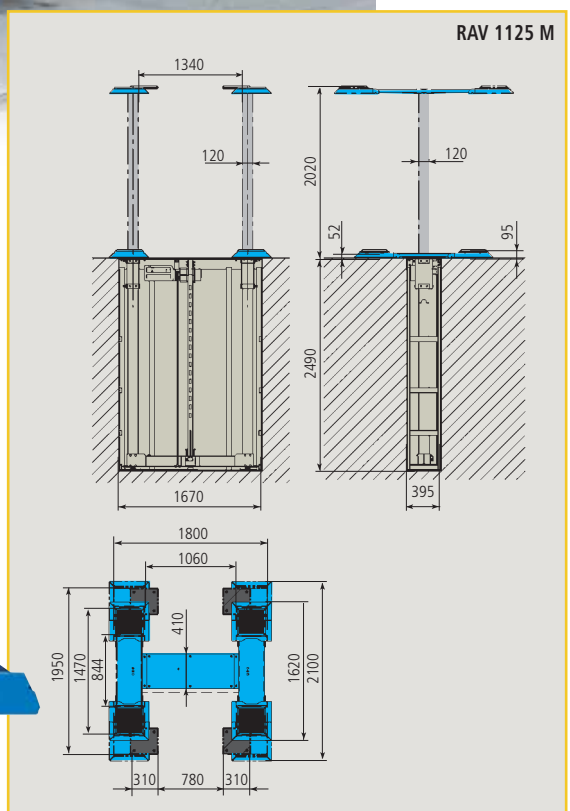



Sollevatore a pedane
Lift with runways
Hebebühne mit Fahrbahnen

RAV 1131 - kg 3.500

Altezza minima da terra 140 mm:
facile accessibilità anche ad auto con spoiler basso.
Limitato ingombro in lunghezza.

*Minimal platforms height 140 mm: easy access also
for cars with low spoilers. Limited length.*

Mindesthöhe vom Fußboden 140 mm; einfaches
Auffahren auch bei Autos mit tiefgelegtem Spoiler.
Begrenztes Ausmaß in der Länge.

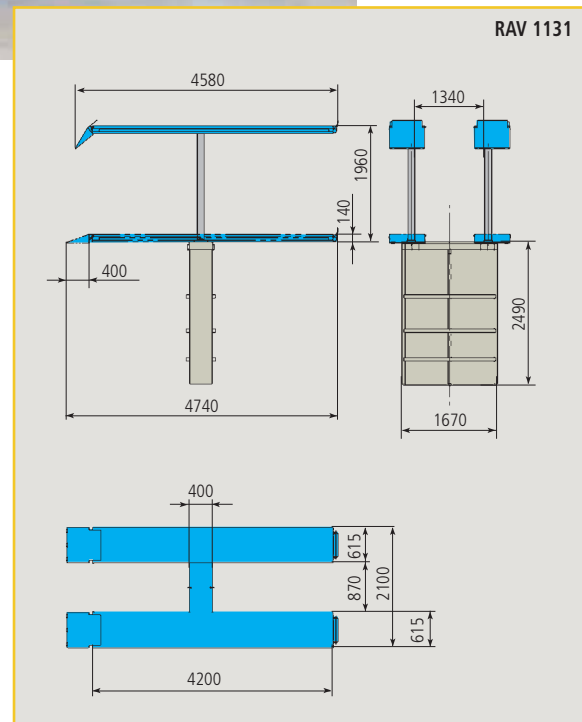

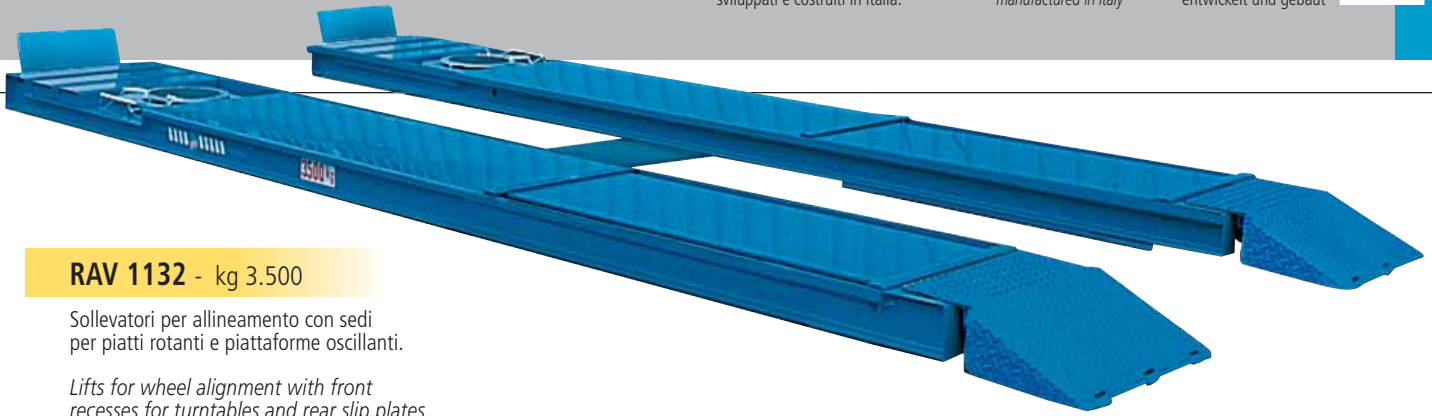

RAV 1132 - kg 3.500

Sollevatori per allineamento con sedi per piatti rotanti e piattaforme oscillanti.

Lifts for wheel alignment with front recesses for turntables and rear slip plates.

Achsmessbühnen mit Aussparungen für Drehteller und Schiebeplatten.

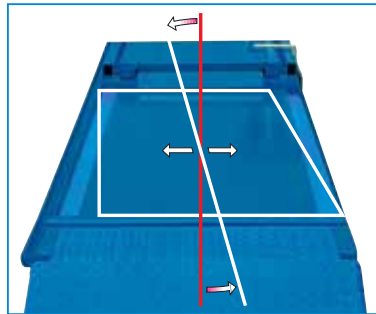
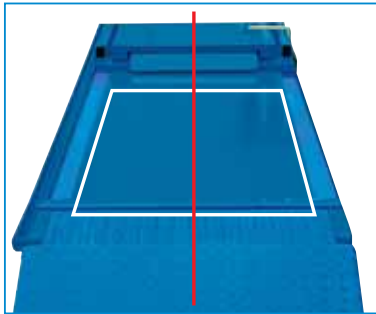

Piattaforme oscillanti con bloccaggio in posizione centrata e movimenti di oscillazione angolare e trasversale in entrambe le direzioni.

Rear slip plates with locking in true position, angular and transversal movements in both directions.

Schiebeplatten mit Arretierung in zentrierter Position sowie Winkel- und Querverschiebung in beiden Richtungen.

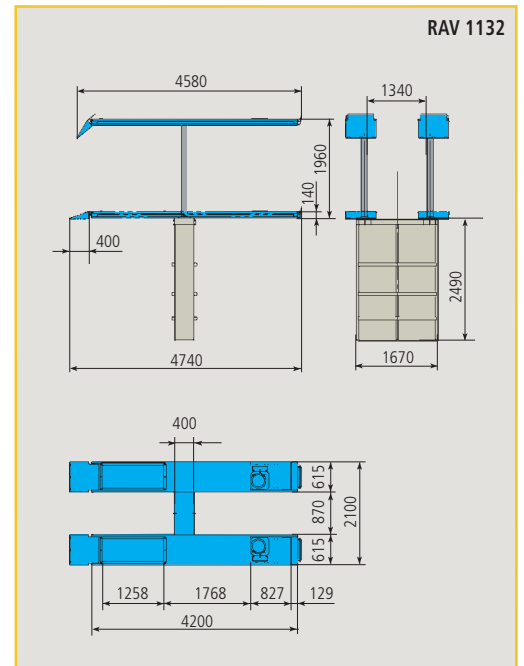

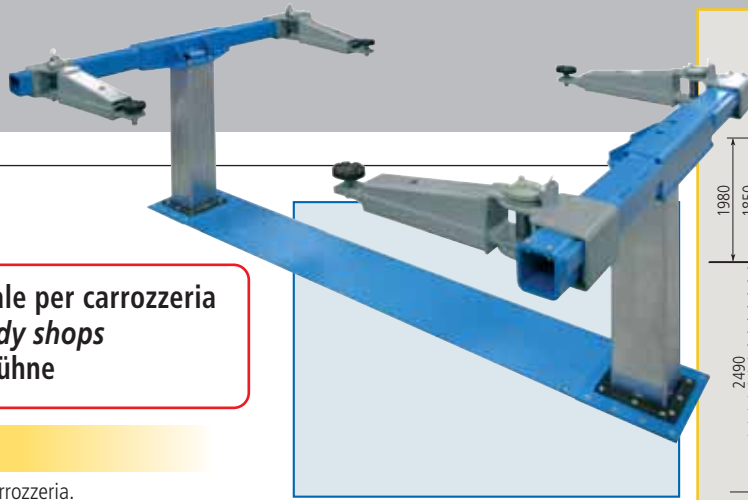

Sollevatore speciale per carrozzeria
Special lift for body shops
Karosserie-Hebebühne

RAV1140 - kg 3.500

Sollevatore speciale per carrozzeria.
 Bracci scorrevoli su due supporti paralleli per il
 posizionamento del veicolo sul banco di riscontro.
 Distanza fra colonne 2.160 mm.

Special lift for body shops.
Arms can be shifted along two lateral supports
to position the vehicle on the body shop bench.
Distance between columns 2.160 mm.

Karosserie-Hebebühne.
 Tragarme längs verschiebbar um das Fahrzeug auf
 die Richtbank stellen zu können.
 Stempelabstand 2.160 mm.

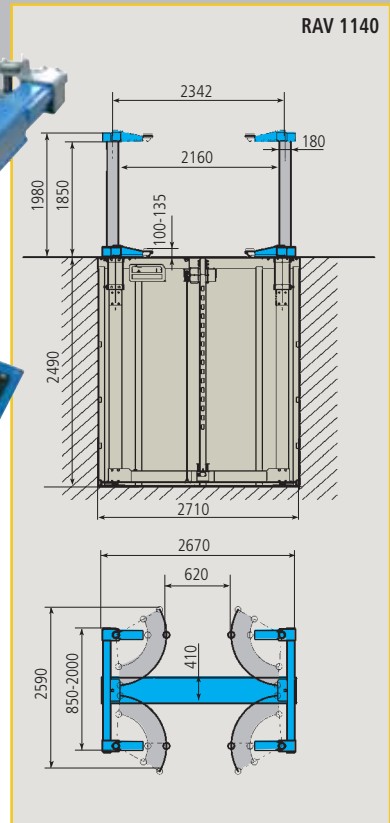

Versioni C
C models
C Ausführungen

Versioni con centralina posizionata in
 una consolle esterna.
 Ideali per zone frequentemente
 bagnate, come le aree di lavaggio.
 Versions with separate power unit.
 Ideal for wet areas like washing bays.
 Versionen mit separatem
 Steueraggregat.
 Ideal für Washanlagen und Nass-
 Stellen.

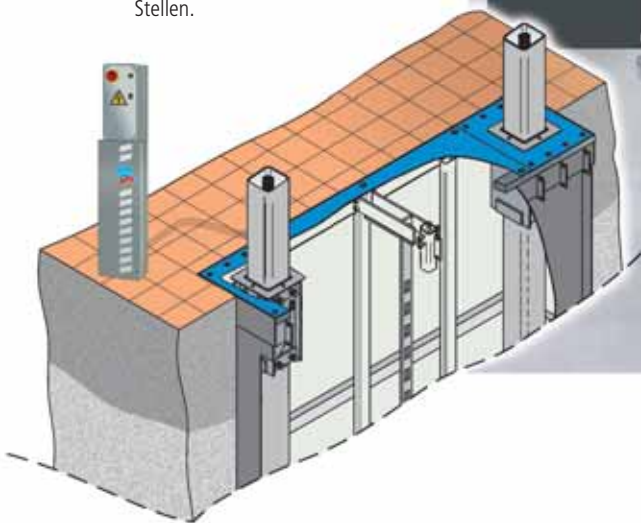

Ravaglioli

Ravaglioli S.p.A.

40037 Sasso Marconi
 Fraz. Pontecchio M.
 P.O.B. 1690 - Bologna - Italia
 Tel. +39 - 051 - 6781511
 Fax +39 - 051 - 846349
 rav@ravaglioli.com
 www.ravaglioli.com

RAV France

6, Rue Longue Raie
 ZAC de la Tremblaie
 91220 Le Plessis Pâté
 Tel. 01.60.86.88.16
 Fax 01.60.86.82.04
 rav@ravfrance.fr

Ravaglioli Deutschland

Kirchenpoint 22
 85354 Freising
 Tel. 08165-646956
 Fax 08165-646958
 info@ravaglioli.de

RAV Equipment UK LTD

1 Kilnhurst Road
 Hooton Roberts, Rotherham
 S65 4PE South Yorkshire
 Tel. 020-76286832
 Fax 020-76286833
 ravuk@ravaglioli.com

RAV en Belgique

Fax 016-781025
 Nederlandstalig
 Tel. 0498-162016
 Zone Francophone
 Tel. 0498-163016

RAV Equipos España

Avenida Europa 17
 Pol. Ind. de Constanti
 Tarragona 43120
 Tel. 977 524525
 Fax 977 524532
 ravequipos@ravaglioli.e.telefonica.net